

DP-11.30.13-VCH

Primary Usage

Reference No.

Sign. and date

Copy inv. No.

Repl. Inv. No.

Sign. and date

Orig. Inv. No.

ITEM NO.	PART NUMBER	DESCRIPTION	QTY
1	DP-11.30.13-VCH.001		1
2	DP-11.30.13-VCH.002		1
3		Square nut DIN 557	1
4	Bolt M6x16 DIN933 (EN ISO 4017)		1

1. To make molding according to GOST 26358-84;
2. Molding accuracy 9-0-0-9 GOST 26 645-85;
3. Unspecified casting slopes 3°, for inscriptions slop 10°
- 3.1 The outer edges of the upper part of the relief round of radius 1,5 mm; the inner edges of the bottom of the relief round of radius 1mm.
- 3.2 The edges of inscriptions round of radius 0,2 mm.
4. On molding allowed:
 - 4.1. Casting defects in the form of shells at any place on the back side of the grating diameter up to 3 mm, depth up to 2mm quantity up to 6 pcs per casting;
 - 4.2. Deflection of the half-mold up to 1,5mm, it does not affect on the basic dimensions of the casting (fastener assemblies, overall).
 - 4.3. Nicks, explosions inside the letters in the marking, provided the readability of the inscriptions
 - 4.4. Balance feeders up to 1mm, it does not affect the overall dimensions of castings
5. Casting paints in black color, thick of painting paint – min 40 mk;
6. On the front side of the casting defect is allowed "rugosity" length up to 15mm, width up to 1mm, depth up to 1mm;
7. On casting junctions is allowed.
 - 7.1. On the front side length up to 10mm, depth up to 1/3 of castings no more than 3 pcs. in the casting without group location
 - 7.2. On the reverse side up to 10 mm, depth up to 5mm, no more than 5 pcs. in the casting without group location
8. Casting clean from molding sand and burning-on, the remains of feeders cut off and clean
9. * - Sizes for notes;
10. Mark the article number – EN 124 C250 Font 6-Пp3 GOST 26.008-85 concave;
11. Mark the date of manufacture of the hatches in the format MMY Y (month, year). Font 5-Pr3 GOST 26.008-85 is concave.
12. To the drawing model L-60.80.16-GGG50-S5.000 STEP is attached, to clarify the geometry of the grating.
13. The font of the main inscriptions Arial is bold 10mm.

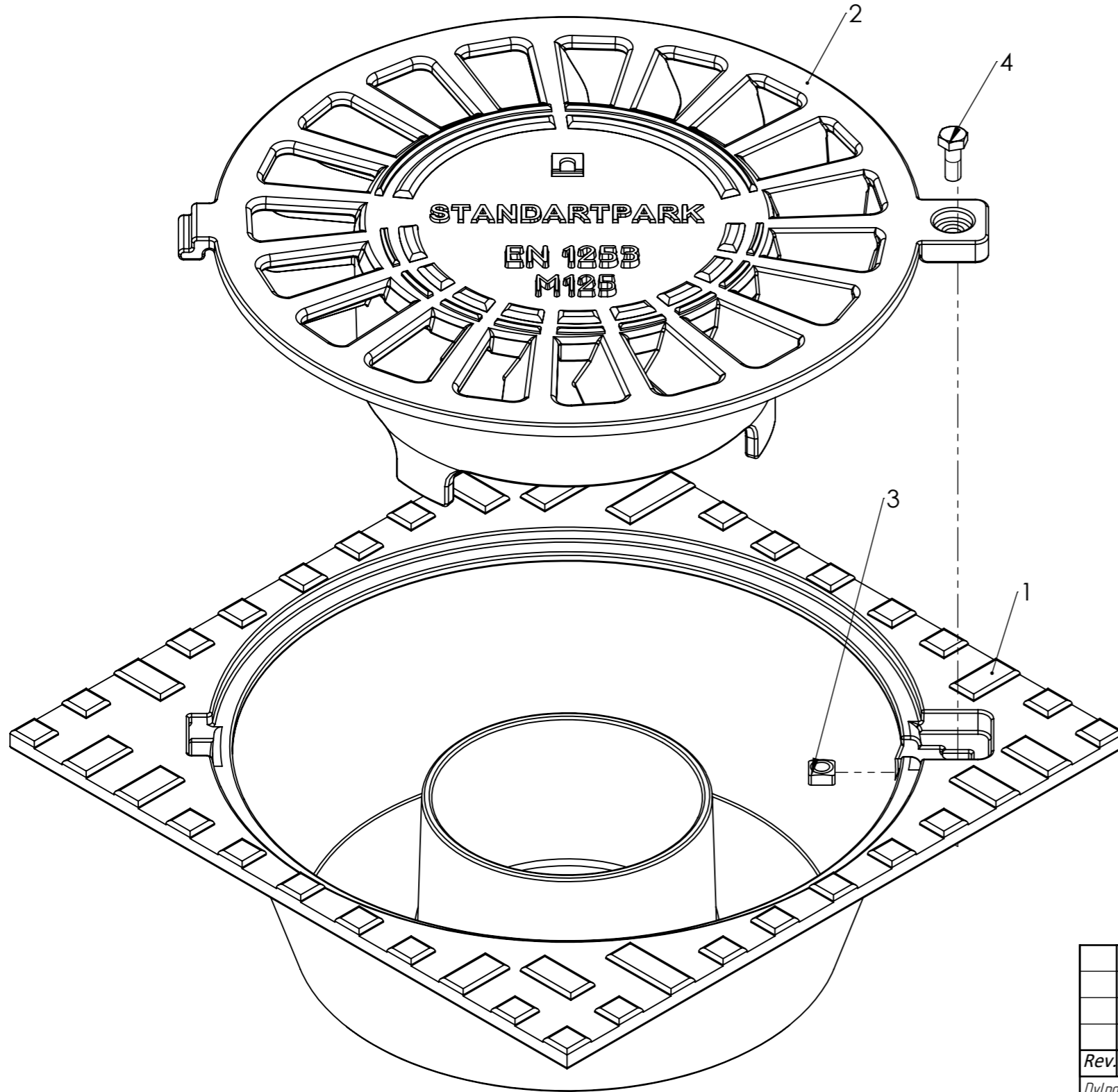

				Art. 3335313-5				
				DP-11.30.13-VCH				
Rev.	Sheet	Doc. No.	Sign.	Data	Trap type M125 GGG50	Let.	Weight (lb)	Scale
							9.26	1:2
						Sheet 1	Sheets 6	
						GGG50		
Reg. Doc. Ctrl	Dyka							
Aprvd by	Darel				Copied by Size A3			

DP-11.30.13-VCH

Primary Usage

Reference No.

Sign. and date

Copy inv. No.

Repl. Inv. No.

Sign. and date

Orig. Inv. No.

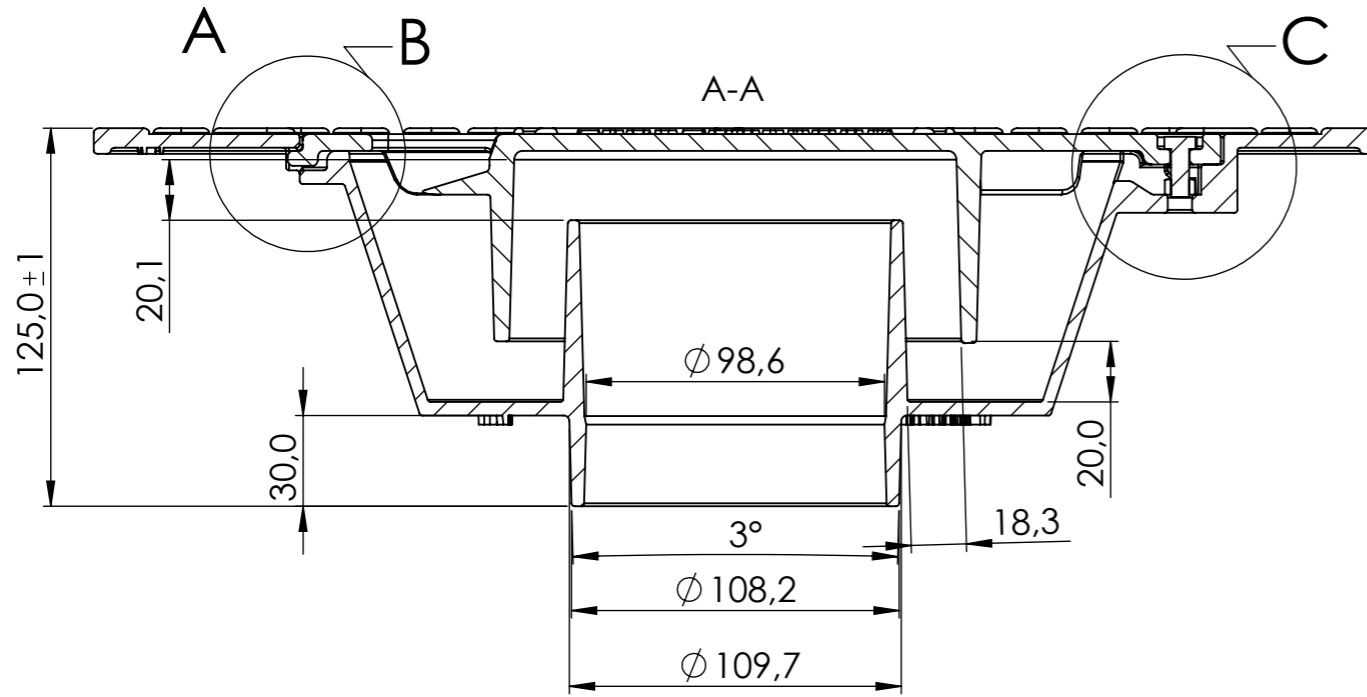
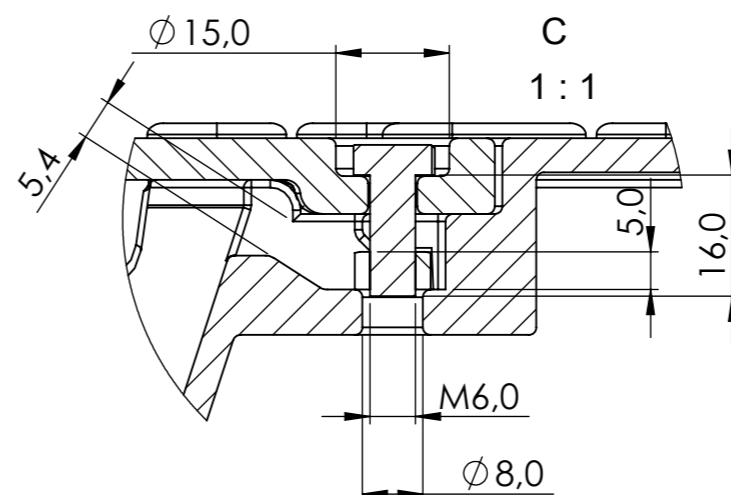
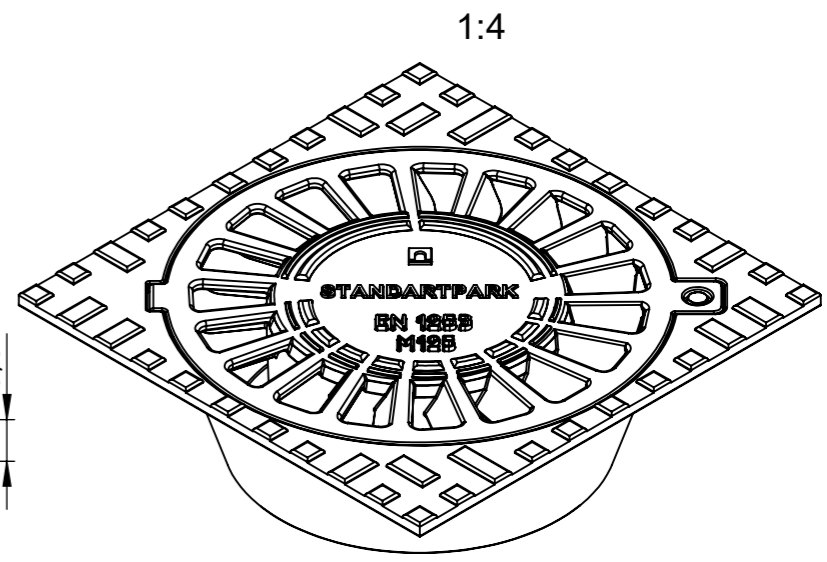
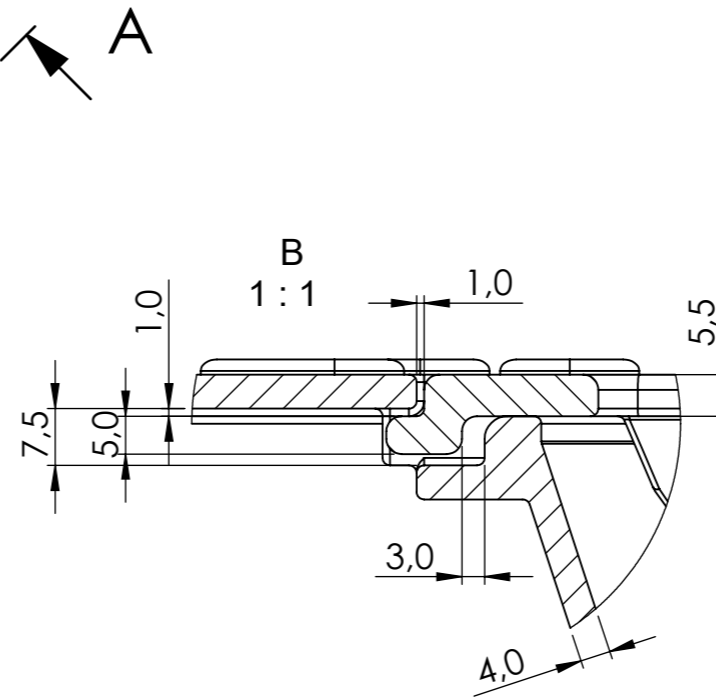
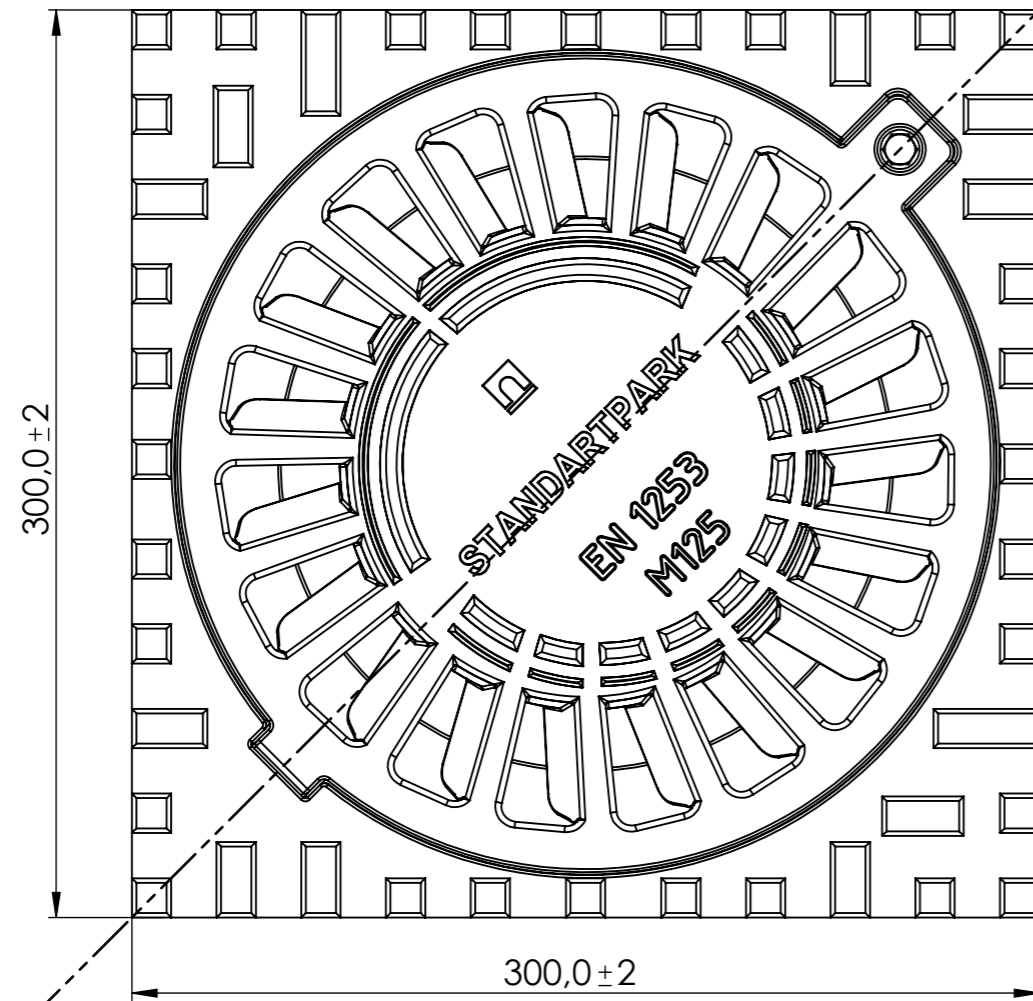

				Art. 3335313-5				
				DP-11.30.13-VCH				
Rev.	Sheet	Doc. No.	Sign.	Data	Trap type M125 GGG50	Let.	Weight (lb)	Scale
							9.26	1:25
						Sheet 2	Sheets 6	
						GGG50		
Reg. Doc. Ctrl	Dyka							
Aprvd by	Darel				Copied by Size A3			

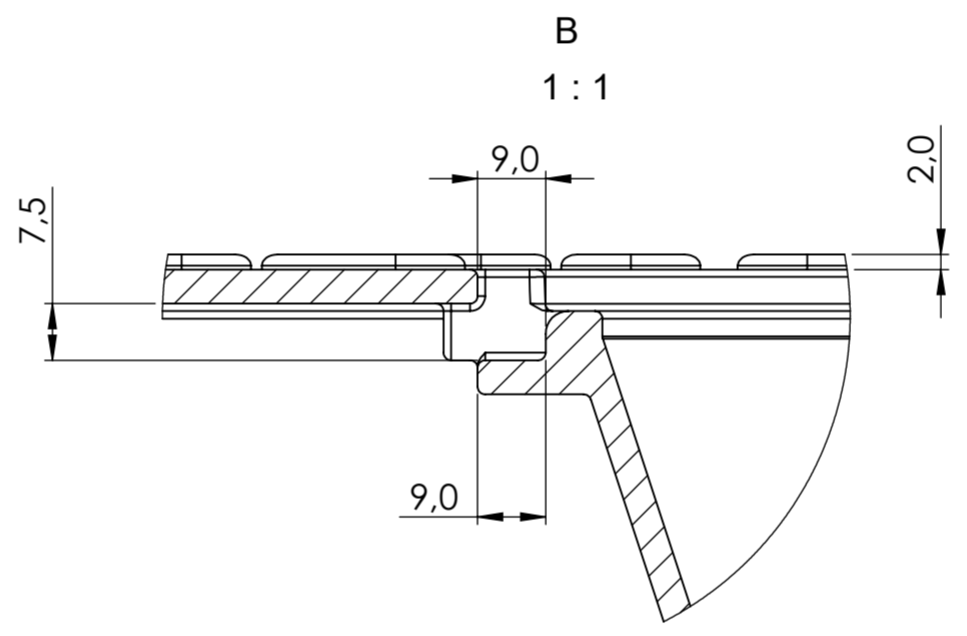
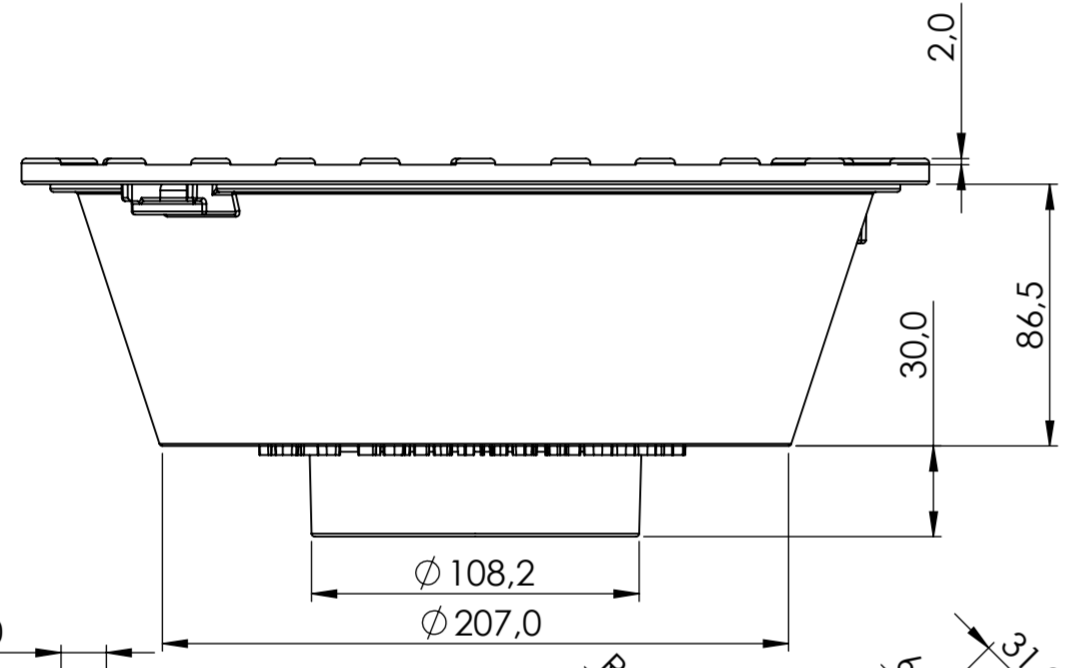
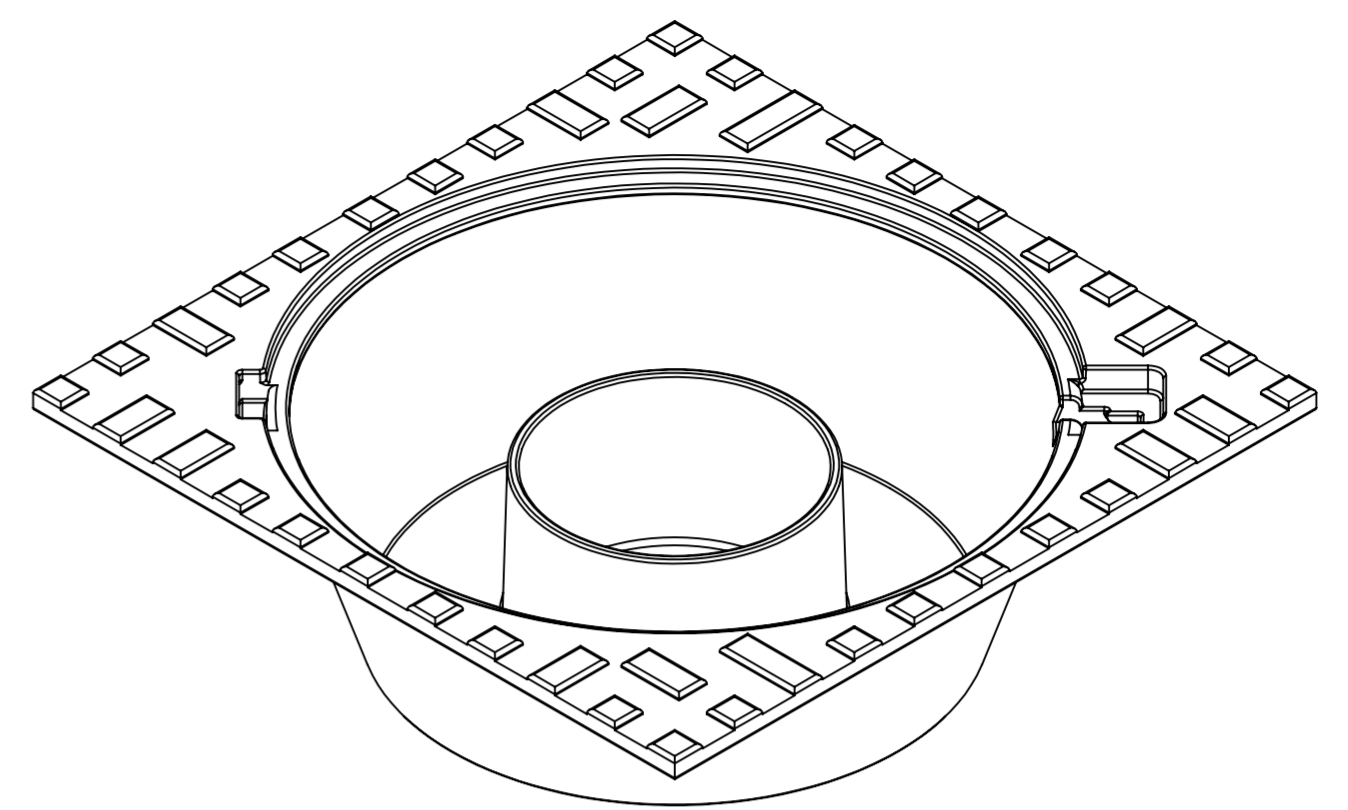
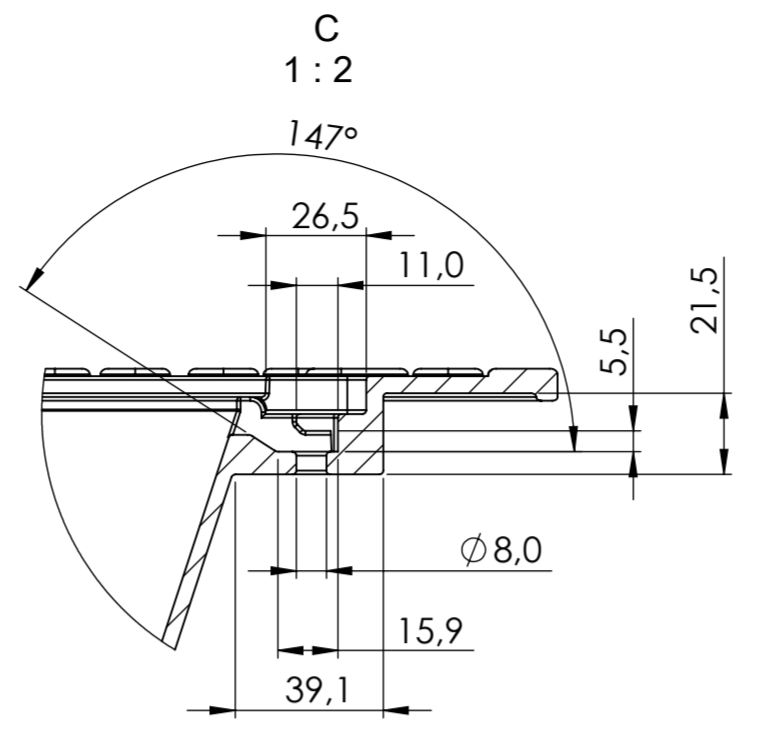
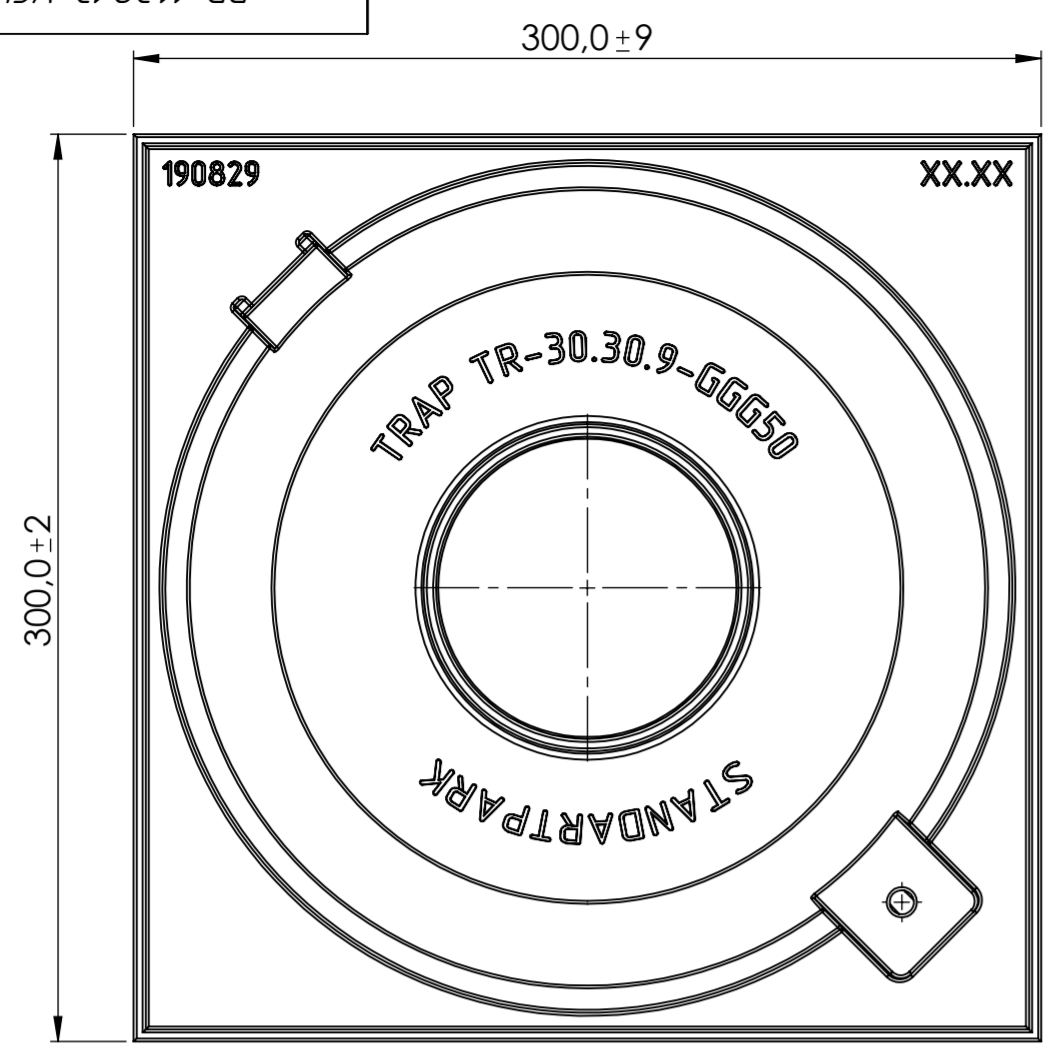

1. To make molding according to GOST 26358-84;
2. Molding accuracy 9-0-0-9 GOST 26 645-85;
3. Unspecified casting slopes 3°, for inscriptions slope 10°
- 3.1 The outer edges of the upper part of the relief round of radius 1.5 mm, the inner edges of the bottom of the relief round of radius 1mm.
- 3.2 The edges of inscriptions round of radius 0.2 mm.
4. On molding allowed:
 - 4.1 Casting defects in the form of shells at any place on the back side of the grating diameter up to 3 mm, depth up to 2mm quantity up to 6 pcs per casting;
 - 4.2 Deflection of the half-mold up to 1.5mm, it does not affect on the basic dimensions of the casting (fastener assemblies, overall).
 - 4.3 Nicks, explosions inside the letters in the marking, provided the readability of the inscriptions
 - 4.4. Balance feeders up to 1mm, it does not affect the overall dimensions of castings
5. Casting paints in black color, thick of painting paint – min 40 мк;
6. On the front side of the casting defect is allowed "rugosity" length up to 15mm, width up to 1mm, depth up to 1mm;
7. On casting junctions is allowed.
 - 7.1. On the front side length up to 10mm, depth up to 1/3 of castings no more than 3 pcs. in the casting without group location
 - 7.2. On the reverse side up to 10 mm, depth up to 5mm, no more than 5 pcs. in the casting without group location
8. Casting clean from molding sand and burning-on, the remains of feeders cut off and clean
9. * - Sizes for notes;
10. Mark the article number – EN 124 C250 Font 6-Пp3 GOST 26.008-85 concave;
11. Mark the date of manufacture of the hatches in the format MMY Y (month, year). Font 5-Pr3 GOST 26.008-85 is concave.
12. To the drawing model L-60.80.16-GGG50-S5.000 STEP is attached, to clarify the geometry of the grating.
13. The font of the main inscriptions Arial is bold 10mm.

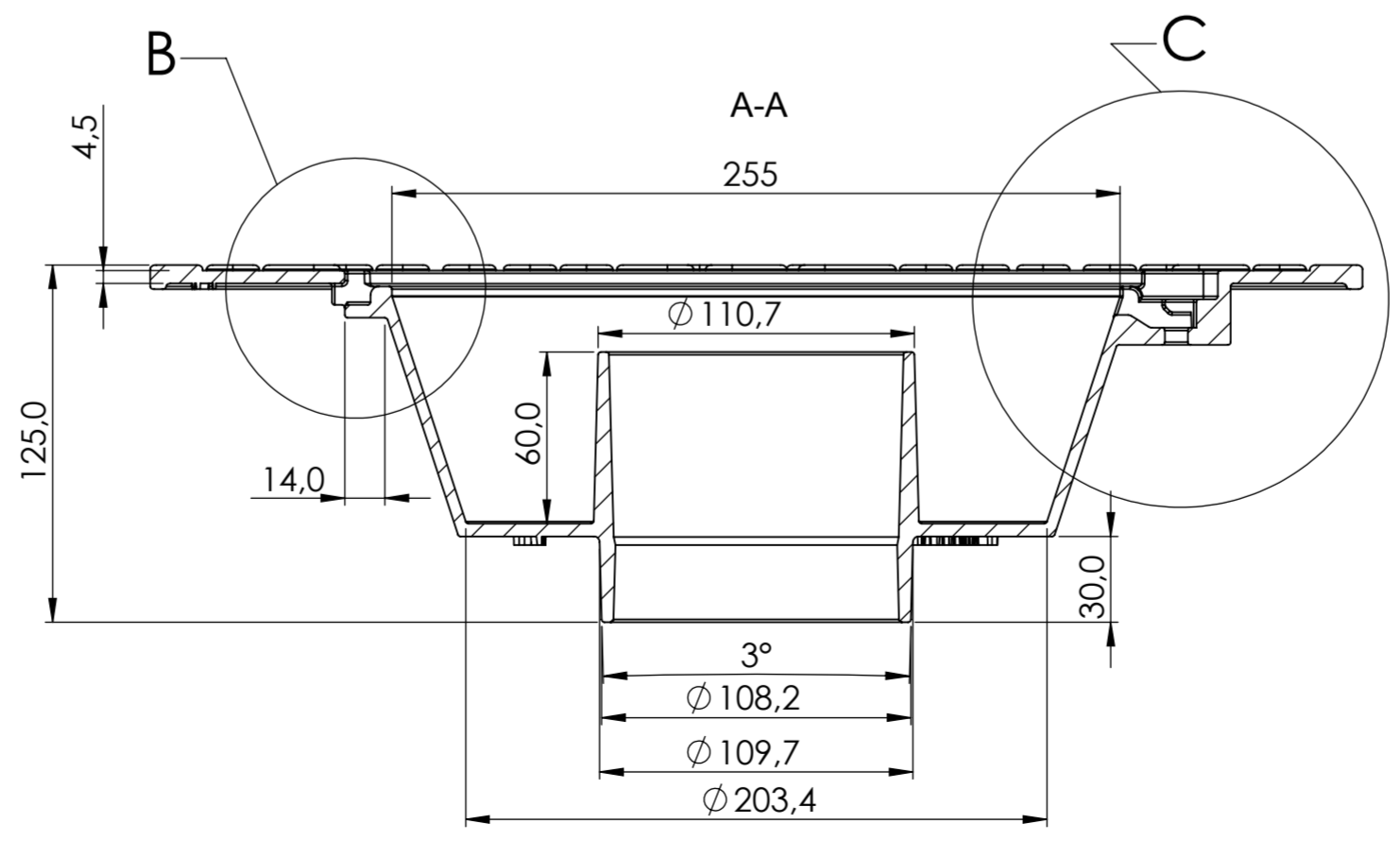
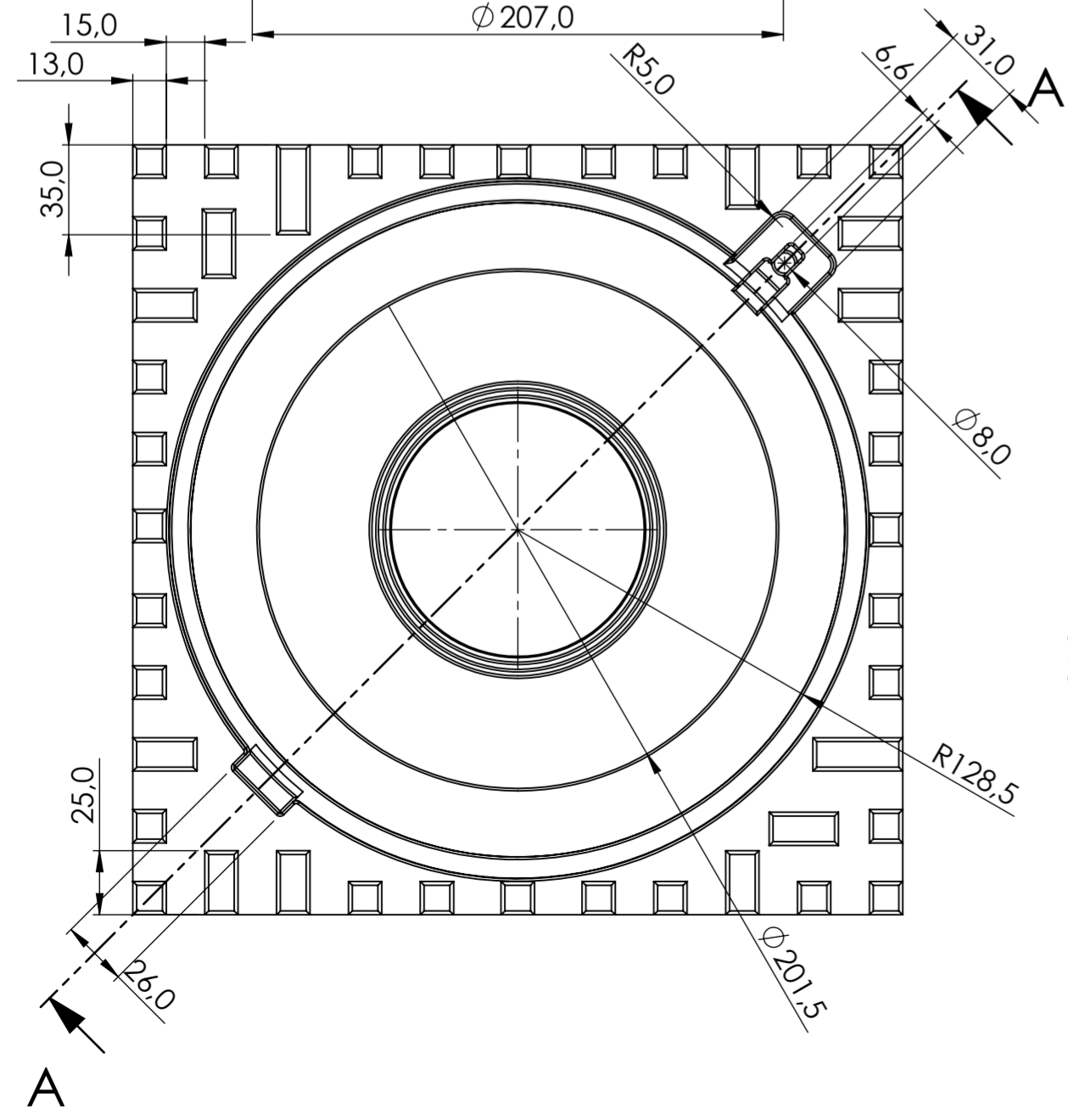

Primary Usage
Reference No.
Sign. and date
Copy inv. No.
Repl. Inv. No.
Sign. and date
Orig. Inv. No.

				Art. 3335313-5			
				DP-11.30.13-VCH.001			
Rev. Sheet	Doc. No.	Sign.	Data	Trap type M125 GGG50	Let.	Weight (lb)	Scale
Dvlpd by	Prakapenka		29.08.2019			5.11	1:2.5
Chkd by	Kachanovskyy			GGG50	Sheet 3	Sheets 6	
Tech. Ctrl	Tsyurak				standartpark		
Reg. Doc. Ctrl	Dyka						
Aprvd by	Darel						

Primary Usage

Reference No.

Sign. and date

Copy inv. No.

Repl. Inv. No.

Sign. and date

Orig. Inv. No.

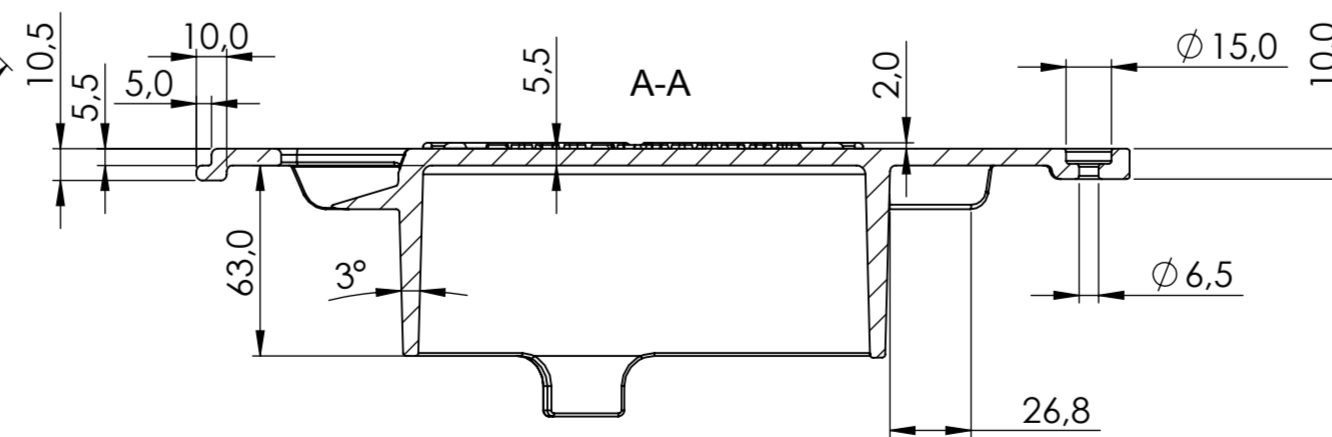
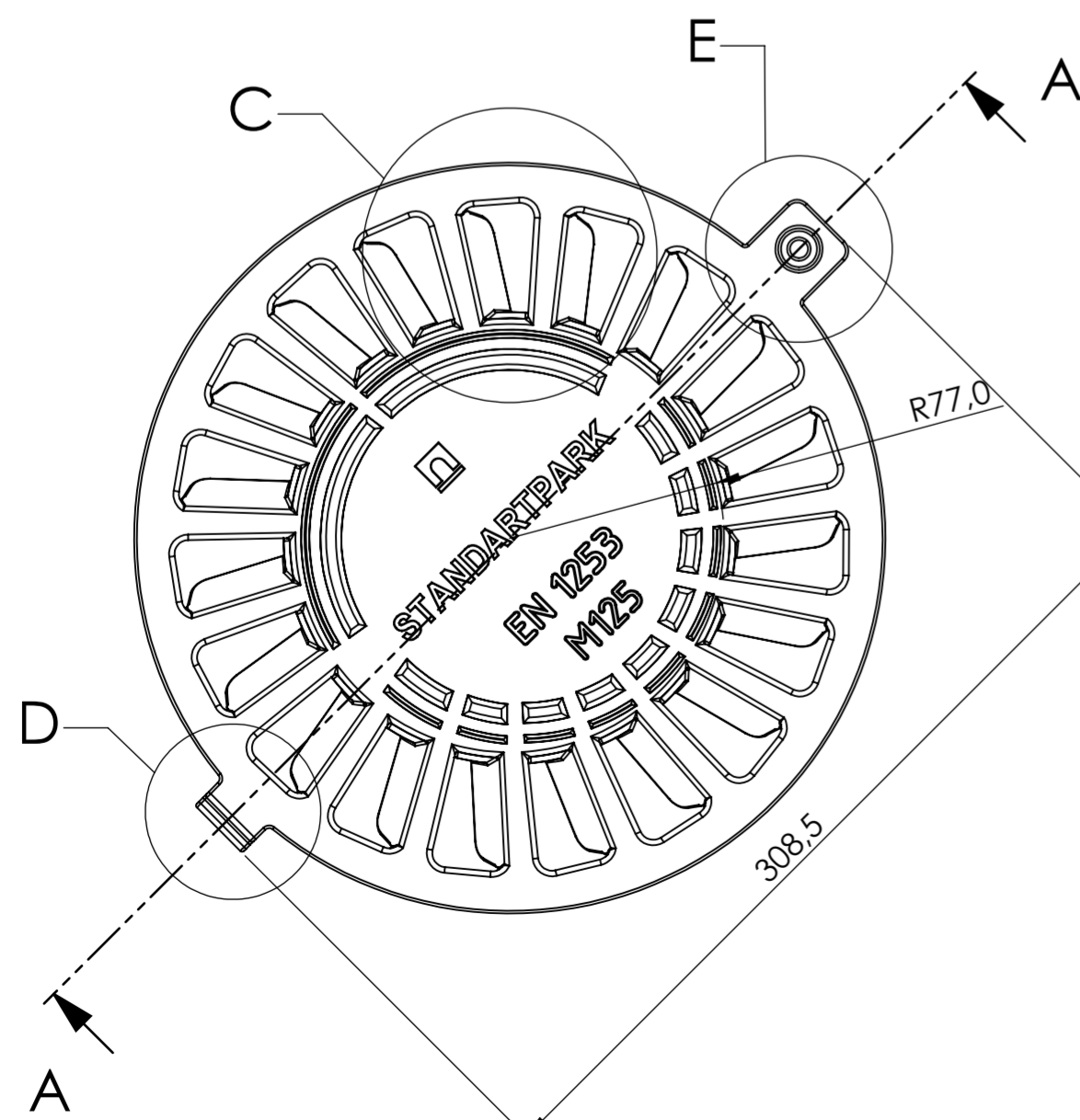
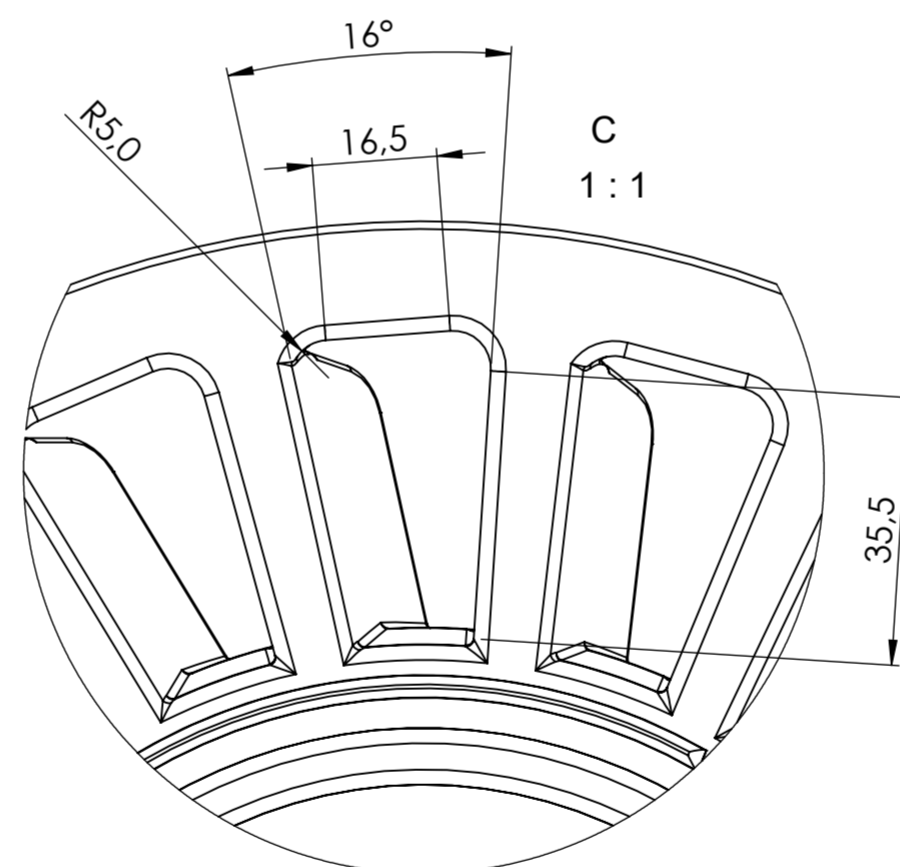
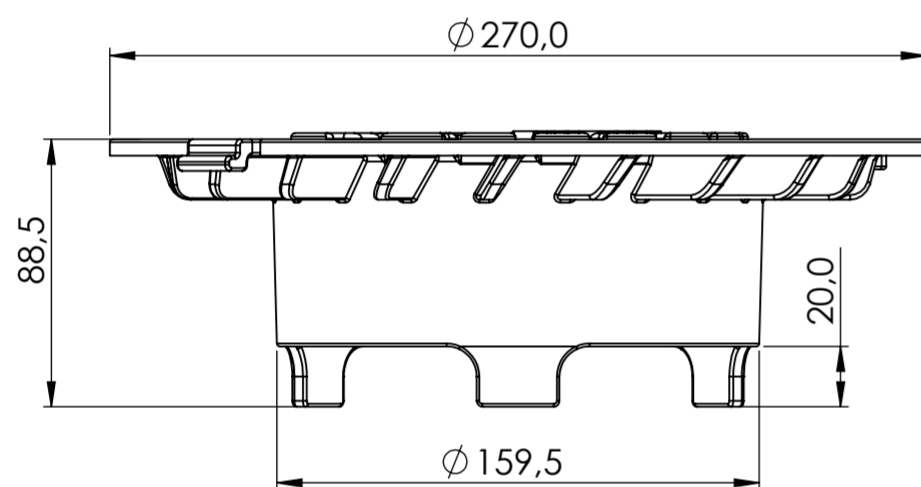
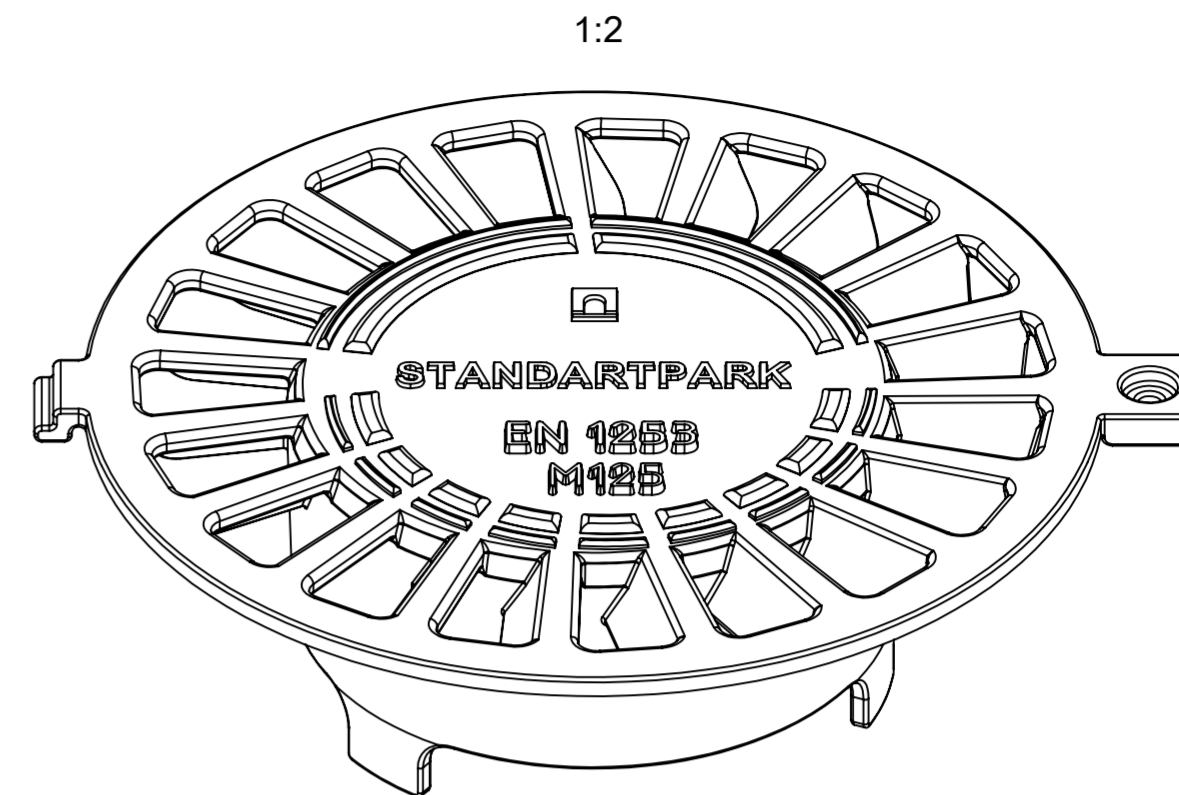
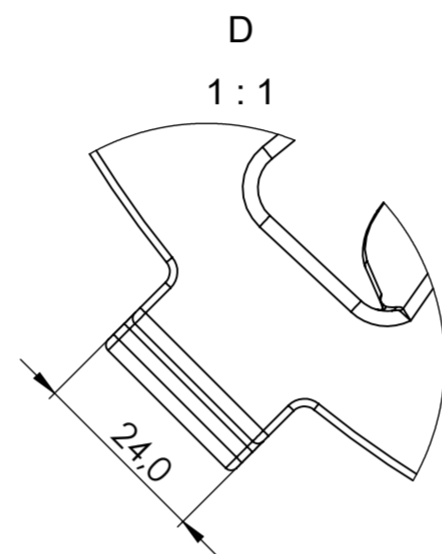
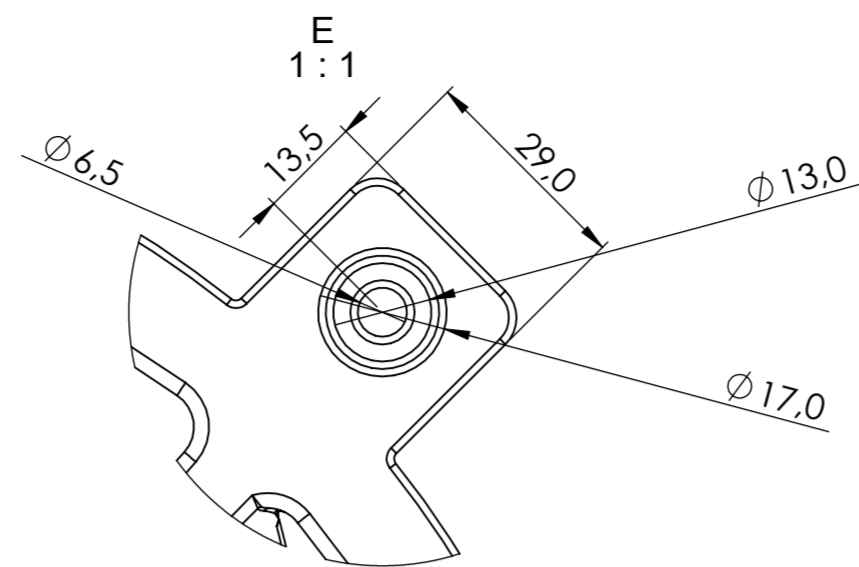
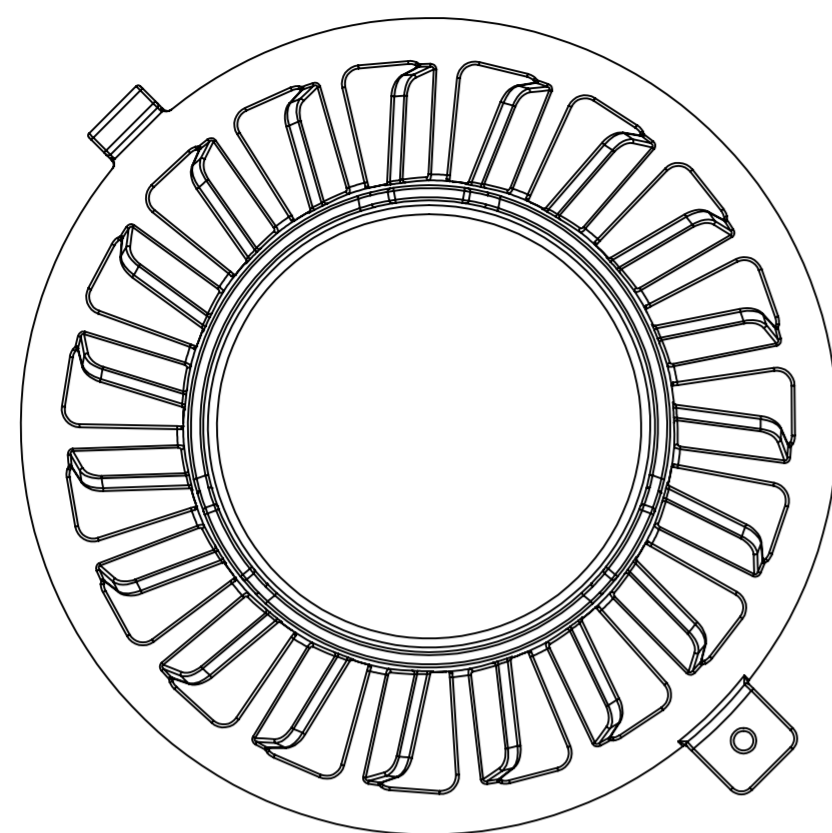

1. To make molding according to GOST 26358-84;
2. Molding accuracy 9-0-0-9 GOST 26 645-85;
3. Unspecified casting slopes 3°, for inscriptions slope 10°
- 3.1 The outer edges of the upper part of the relief round of radius 1.5 mm, the inner edges of the bottom of the relief round of radius 1 mm.
- 3.2 The edges of inscriptions round of radius 0.2 mm.
4. On molding allowed:
 - 4.1 Casting defects in the form of shells at any place on the back side of the grating diameter up to 3 mm, depth up to 2 mm quantity up to 6 pcs per casting;
 - 4.2 Deflection of the half-mold up to 1.5 mm, it does not affect on the basic dimensions of the casting (fastener assemblies, overall).
 - 4.3 Nicks, explosions inside the letters in the marking, provided the readability of the inscriptions
 - 4.4 Balance feeders up to 1 mm, it does not affect the overall dimensions of castings
5. Casting paints in black color, thick of painting paint - min 40 mk;
6. On the front side of the casting defect is allowed "rugosity" length up to 15 mm, width up to 1 mm, depth up to 1 mm;
7. On casting junctions is allowed
 - 7.1. On the front side length up to 10 mm, depth up to 1/3 of castings no more than 3 pcs. in the casting without group location
 - 7.2. On the reverse side up to 10 mm, depth up to 5 mm, no more than 5 pcs. in the casting without group location
8. Casting clean from molding sand and burning-on, the remains of feeders cut off and clean
9. * - Sizes for notes;
10. Mark the article number - EN 124 C250 Font 6-Пp3 GOST 26.008-85 concave;
11. Mark the date of manufacture of the hatches in the format MMY (month, year). Font 5-Pr3 GOST 26.008-85 is concave.
12. To the drawing model L-60.80.16-GGG50-S5.000 STEP is attached, to clarify the geometry of the grating.
13. The font of the main inscriptions Arial is bold 10 mm.

				DP-11.30.13-VCH.002			Art. 3335313-5	
Rev.	Sheet	Doc. No.	Sign.	Data	Trap type M125 GGG50	Let.	Weight (lb)	Scale
				29.08.2019			3.28	1:2.5
						Sheet 4	Sheets 6	
Reg. Doc. Ctrl.	Dyka				GGG50			
Aprvd by	Darel							

DP-11.30.13-VCH

Primary Usage

Reference No.

Sign. and date

Copy inv. No.

Repl. Inv. No.

Sign. and date

Orig. Inv. No.

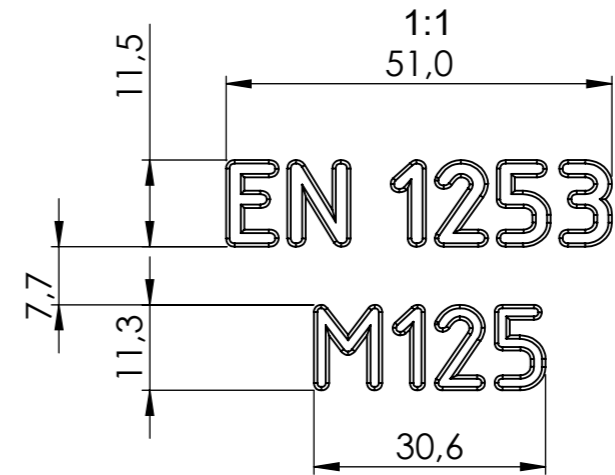
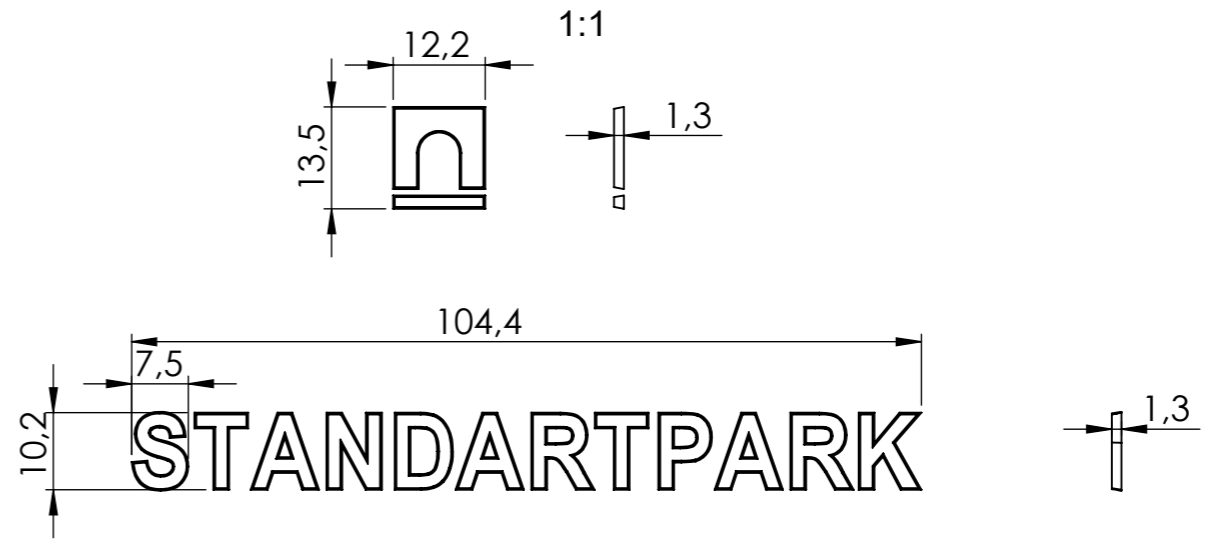
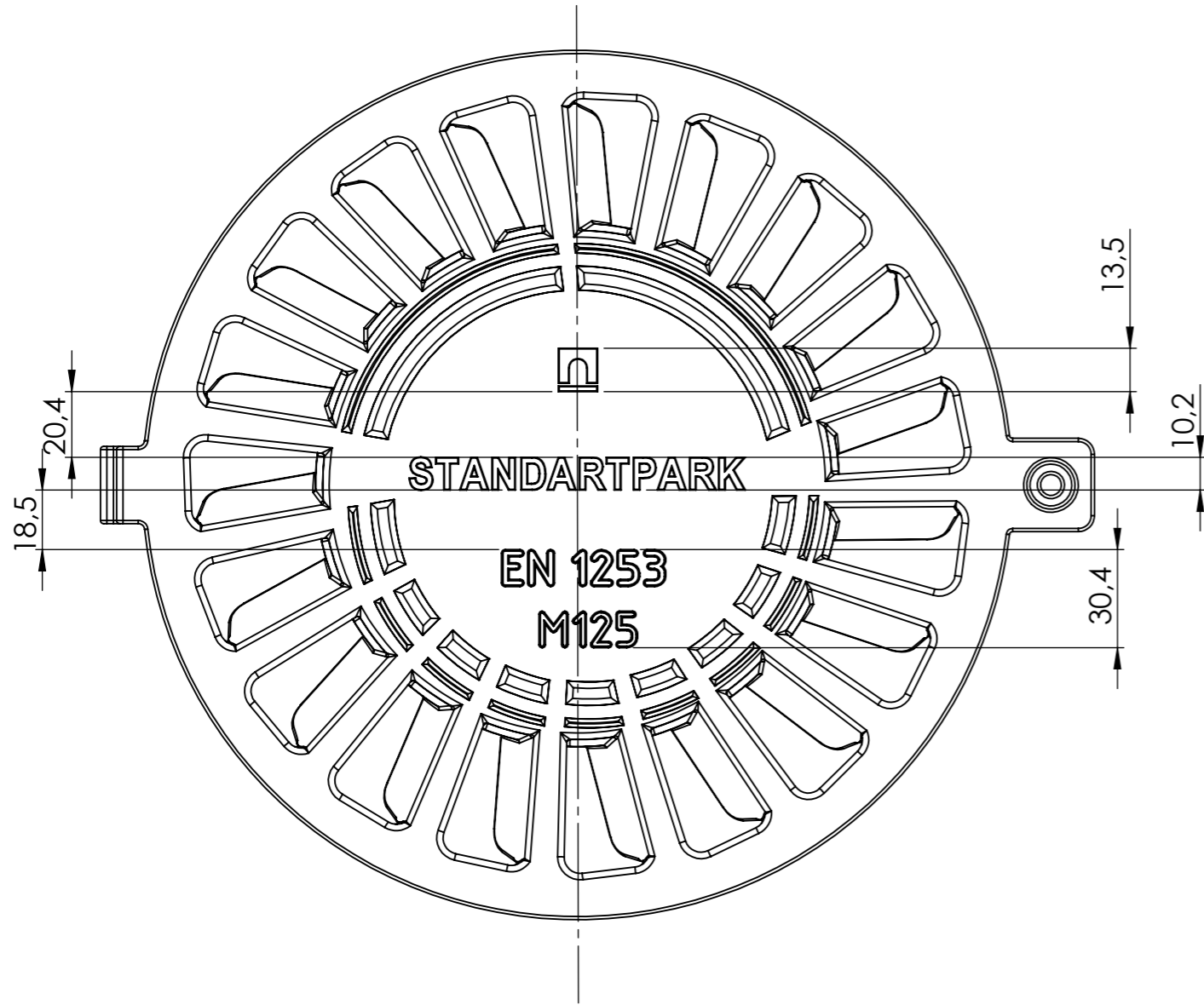

				DP-11.30.13-VCH			Art.	3335313-5
Rev.	Sheet	Doc. No.	Sign.	Data	Cover "Inscriptions on top"	Let.	Weight (lb)	Scale
				29.08.2019			9.26	1:25
Dvlpd by		Prakopenko				Sheet 5	Sheets 6	
Chkd by		Kachanovskyy						
Tech. Ctrl		Tsyurak						
Reg. Doc. Ctrl		Dyka			GGG50			
Aprvd by		Darel						

Copied by

Size A3

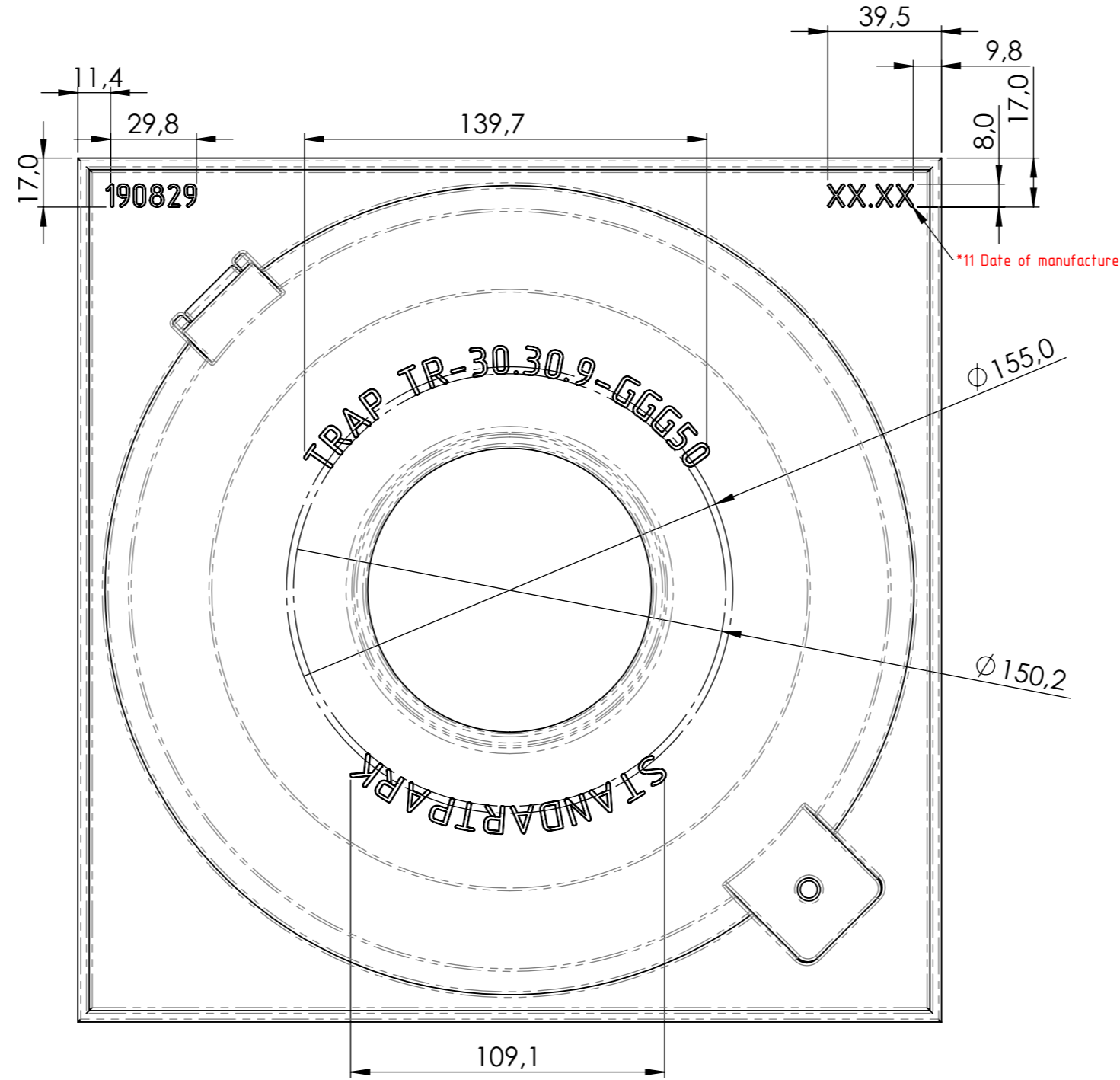

				DP-11.30.13-VCH			Art. 3335313-5		
Rev.	Sheet	Doc. No.	Sign.	Data	Cover "Marking bottom"	Let.	Weight (lb)	Scale	
								9.26	1:25
Dvlpd by		Prakopenko		29.08.2019					
Chkd by		Kachanovskyy							
Tech. Ctrl		Tsyurak				Sheet 6		Sheets 6	
Reg. Doc. Ctrl		Dyka			GGG50				
Aprvd by		Darel							